

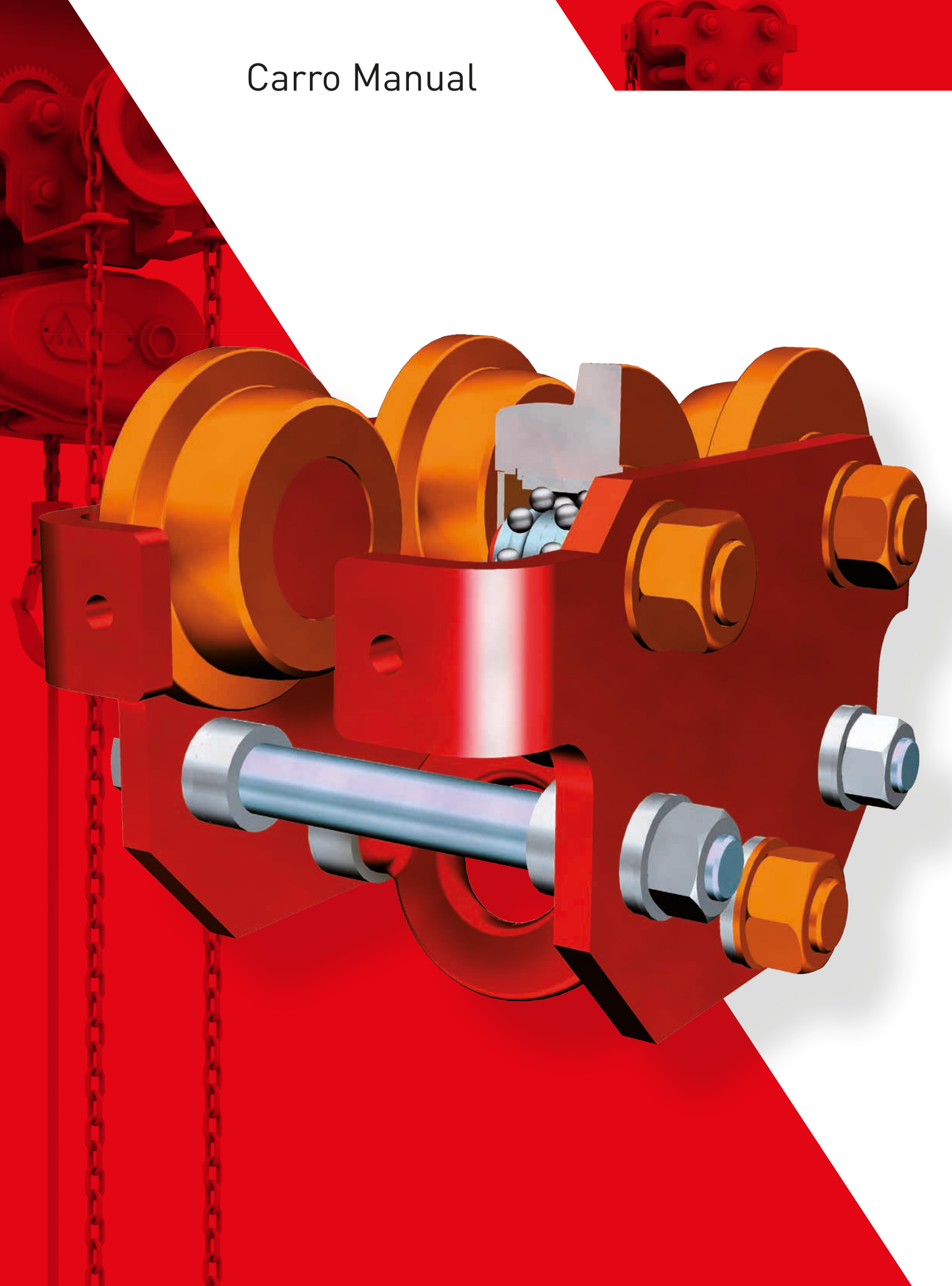





Carro Manual



Principales ventajas

	<p>Máxima seguridad</p>	<p>Placas laterales anticaídas.</p>
	<p>Versatilidad</p>	<p>Adaptables al desplazamiento por cualquier tipo de viga (recta, curva o mixta).</p>
	<p>Facilmente Ajustable</p>	<p>Hasta cinco vigas diferentes, por modelo, simplemente cambiando la posición de las arandelas.</p>
	<p>Máxima Vida Util</p>	<p>Construido para trabajar a plena carga en las condiciones más severas durante muchos años.</p>
	<p>Gran resistencia</p>	<p>Fabricados con los mejores materiales para garantizar su durabilidad: ruedas anticorrosión, rodamientos de bolas de acero...</p>
	<p>Máxima Garantía</p>	<p>5 AÑOS de garantía básica.</p>



Carro Manual

Carro Manual Amenabar

Carro de Polipastos:

Nuestros carros manuales se adaptan a cualquier tipo de viga cuya anchura de ala esté entre los valores indicados en nuestra tabla de características.

Ofrecemos la posibilidad, bajo petición del cliente, de adaptar nuestros carros a cualquier tipo y dimensiones de viga, siempre que resulte técnicamente viable.

Características y Dimensiones de los Carros Manuales Amenabar

Carro S-T (sin traslación) de 500 a 3.200 Kg

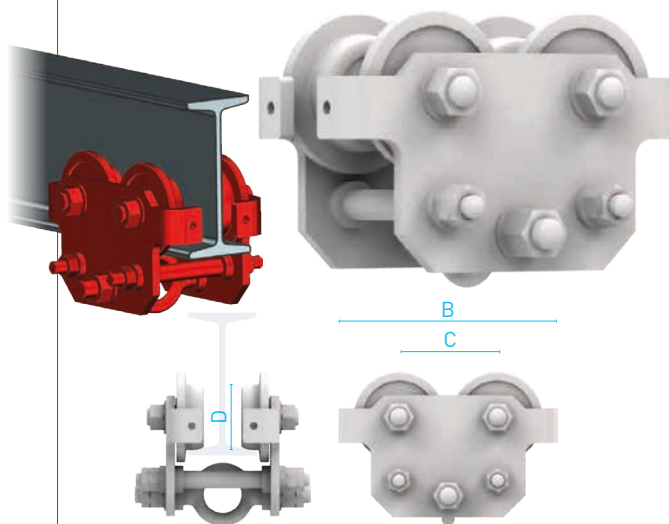

Carro C-T (con traslación) de 500 a 16.000 Kg.

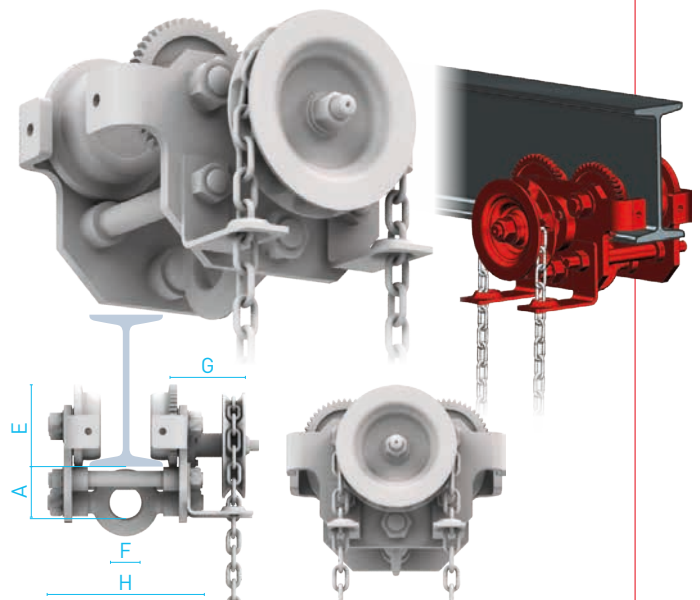

Opción de Cabezas Articuladas, para puentes articulados suspendidos.

Adaptación vigas Polipastos Eléctricos

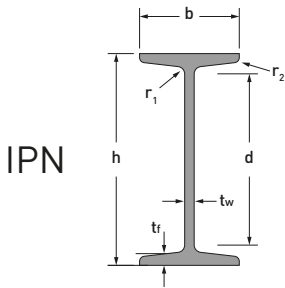

IPN

		IPN																					
		80x42	100x50	120x58	140x66	160x74	180x82	200x90	220x98	240x106	260x113	280x119	300x125	320x131	340x137	360x143	380x149	400x155	450x170	500x185	550x200	600x215	
KG	AK-150																						
	AK-250																						
	AK-350																						
	AK-500																						
	BK-500																						
	BK-750																						
	BK-1000																						
	BK-1500																						
	CK-1000																						
	CK-1500																						
	CK-2000																						
	CK-2500																						
	CK-3200																						
	CK-4000																						
	EK																						

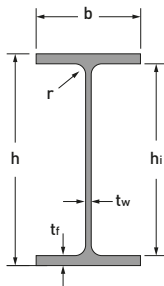

IPE

		IPE																		
		80x46	100x55	120x64	140x73	160x82	180x91	200x100	220x110	240x120	270x135	300x150	330x160	360x170	400x180	450x190	500x200	550x210	600x220	
KG	AK-150																			
	AK-250																			
	AK-350																			
	AK-500																			
	BK-500																			
	BK-750																			
	BK-1000																			
	BK-1500																			
	CK-1000																			
	CK-1500																			
	CK-2000																			
	CK-2500																			
	CK-3200																			
	CK-4000																			
EK																				

Compatible carro estándar. Carro especial a medida. Incompatible.

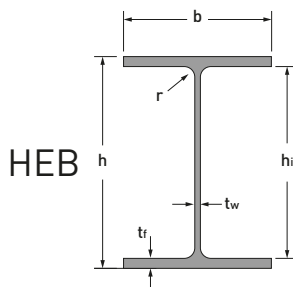

		HEB																		
MOD.	KG	100	120	140	160	180	200	220	240	260	280	300	320	340	360	400	450	500	550	600
AK-150																				
AK-250																				
AK-350																				
AK-500																				
BK-500																				
BK-750																				
BK-1000																				
BK-1500																				
CK-1000																				
CK-1500																				
CK-2000																				
CK-2500																				
CK-3200																				
CK-4000																				
EK																				

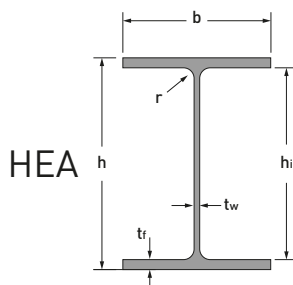

		HEA																																		
MOD.	KG	96x100	114x120	133x140	152x160	171x180	190x200	210x220	220	230x240	240	250x260	260	270x280	280	290x300	300	310x300	320	330x300	340	350x300	360	390x300	400	440x300	450	490x300	500	540x300	550	590x300	600			
AK-150																																				
AK-250																																				
AK-350																																				
AK-500																																				
BK-500																																				
BK-750																																				
BK-1000																																				
BK-1500																																				
CK-1000																																				
CK-1500																																				
CK-2000																																				
CK-2500																																				
CK-3200																																				
CK-4000																																				
EK																																				

Compatible carro estándar.

Carro especial a medida.

Incompatible.

Adaptación vigas Polipastos Manuales

IPN

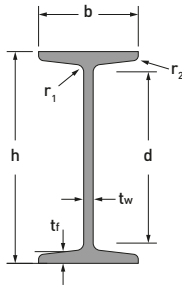

		IPN																				
		80x42	100x50	120x58	140x66	160x74	180x82	200x90	220x98	240x106	260x113	280x119	300x125	320x131	340x137	360x143	380x149	400x155	450x170	500x185	550x200	600x215
KG	M1-500																					
	M2-1000																					
	M3-1600																					
	M3-2000																					
	M4-2000																					
	M4-2500																					
	M3-3200																					
	M4-5000																					
	M5-6300																					
	M5-8000																					
	M5-10000																					
	M5-12500																					
	M5-16000																					

IPE

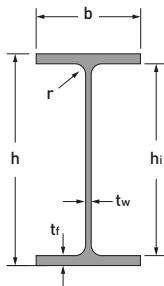

		IPE																			
		80x46	100x55	120x64	140x73	160x82	180x91	200x100	220x110	240x120	270x135	300x150	330x160	360x170	400x180	450x190	500x200	550x210	600x220		
KG	M1-500																				
	M2-1000																				
	M3-1600																				
	M3-2000																				
	M4-2000																				
	M4-2500																				
	M3-3200																				
	M4-5000																				
	M5-6300																				
	M5-8000																				
	M5-10000																				
	M5-12500																				
	M5-16000																				

Compatible carro estándar.

Carro especial a medida.

Incompatible.

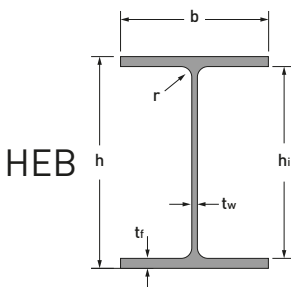

		HEB																		
MODELO		100	120	140	160	180	200	220	240	260	280	300	320	340	360	400	450	500	550	600
	KG	100x100	120x120	140x140	160x160	180x180	200x200	220x220	240x240	260x260	280x280	300x300	320x300	340x300	360x300	400x300	450x300	500x300	550x300	600x300
M1-500																				
M2-1000																				
M3-1600																				
M3-2000																				
M4-2000																				
M4-2500																				
M3-3200																				
M4-5000																				
M5-6300																				
M5-8000																				
M5-10000																				
M5-12500																				
M5-16000																				

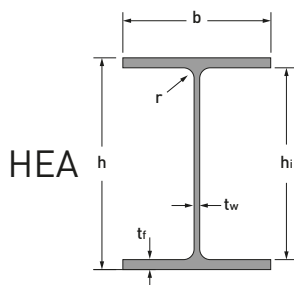

		HEA																		
MODELO		100	120	140	160	180	200	220	240	260	280	300	320	340	360	400	450	500	550	600
	KG	96x100	114x120	133x140	152x160	171x180	190x200	210x220	230x240	250x260	270x280	290x300	310x300	330x300	350x300	390x300	440x300	490x300	540x300	590x300
M1-500																				
M2-1000																				
M3-1600																				
M3-2000																				
M4-2000																				
M4-2500																				
M3-3200																				
M4-5000																				
M5-6300																				
M5-8000																				
M5-10000																				
M5-12500																				
M5-16000																				

Compatible carro estándar. Carro especial a medida. Incompatible.

Aparatos de elevación

Adaptación vigas Carros Manuales

IPN

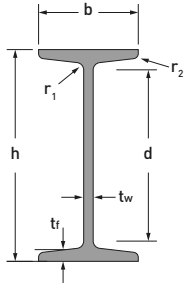

		IPN																					
		80x42	100x50	120x58	140x66	160x74	180x82	200x90	220x98	240x106	260x113	280x119	300x125	320x131	340x137	360x143	380x149	400x155	450x170	500x185	550x200	600x215	
KG	T1-500																						
	T2-1000																						
	T3-1600																						
	T3-2000																						
	T4-3200																						
	T5-5000																						
	T5-6300																						
	T6-8000																						
	T6-10000																						

IPE

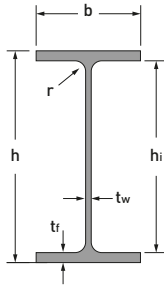

		IPE																				
		80x46	100x55	120x64	140x73	160x82	180x91	200x100	220x110	240x120	270x135	300x150	330x160	360x170	400x180	450x190	500x200	550x210	600x220			
KG	T1-500																					
	T2-1000																					
	T3-1600																					
	T3-2000																					
	T4-3200																					
	T5-5000																					
	T5-6300																					
	T6-8000																					
	T6-10000																					

Compatible carro estándar.

Carro especial a medida.

Incompatible.

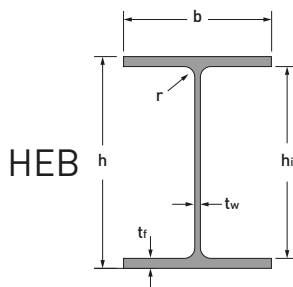

		HEB																		
MODELO		100	120	140	160	180	200	220	240	260	280	300	320	340	360	400	450	500	550	600
KG		100x100	120x120	140x140	160x160	180x180	200x200	220x220	240x240	260x260	280x280	300x300	320x300	340x300	360x300	400x300	450x300	500x300	550x300	600x300
T1-500																				
T2-1000																				
T3-1600																				
T3-2000																				
T4-3200																				
T5-5000																				
T5-6300																				
T6-8000																				
T6-10000																				

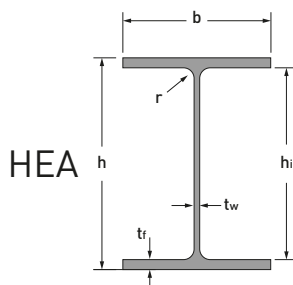

		HEA																		
MODELO		100	120	140	160	180	200	220	240	260	280	300	320	340	360	400	450	500	550	600
KG		96x100	114x120	133x140	152x160	171x180	190x200	210x220	230x240	250x260	270x280	290x300	310x300	330x300	350x300	390x300	440x300	490x300	540x300	590x300
T1-500																				
T2-1000																				
T3-1600																				
T3-2000																				
T4-3200																				
T5-5000																				
T5-6300																				
T6-8000																				
T6-10000																				

Compatible carro estándar.

Carro especial a medida.

Incompatible.

Carro Manual

Ruedas:

De fundición gris mecanizada válidas para cualquier tipo de perfil.

Rodamientos de Bolas:

De gran capacidad de carga que facilitan el deslizamiento del carro sobre la viga.

Freno de Seguridad:

Patentado, de accionamiento frontal, que agiliza los descensos y reduce el esfuerzo a realizar para bajar cargas.

Placas laterales anticaídas:

Máxima seguridad.

Cuerpo Principal:

Construcción mediante dos soportes laterales, unidos con dos separadores y un yugo central, dotándole de mayor rigidez y seguridad al conjunto del carro.

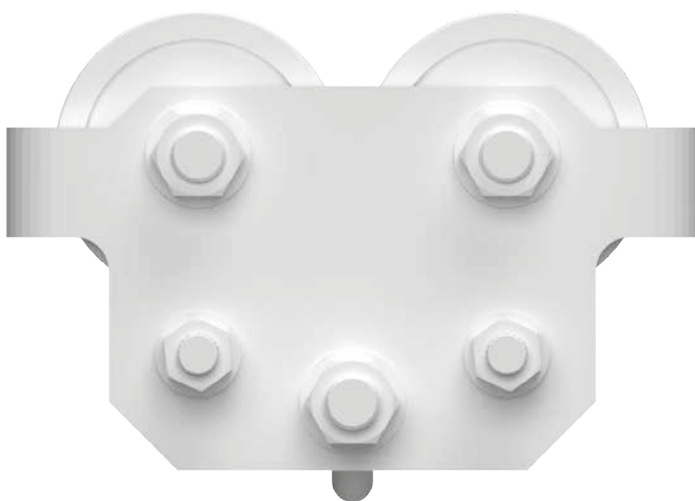
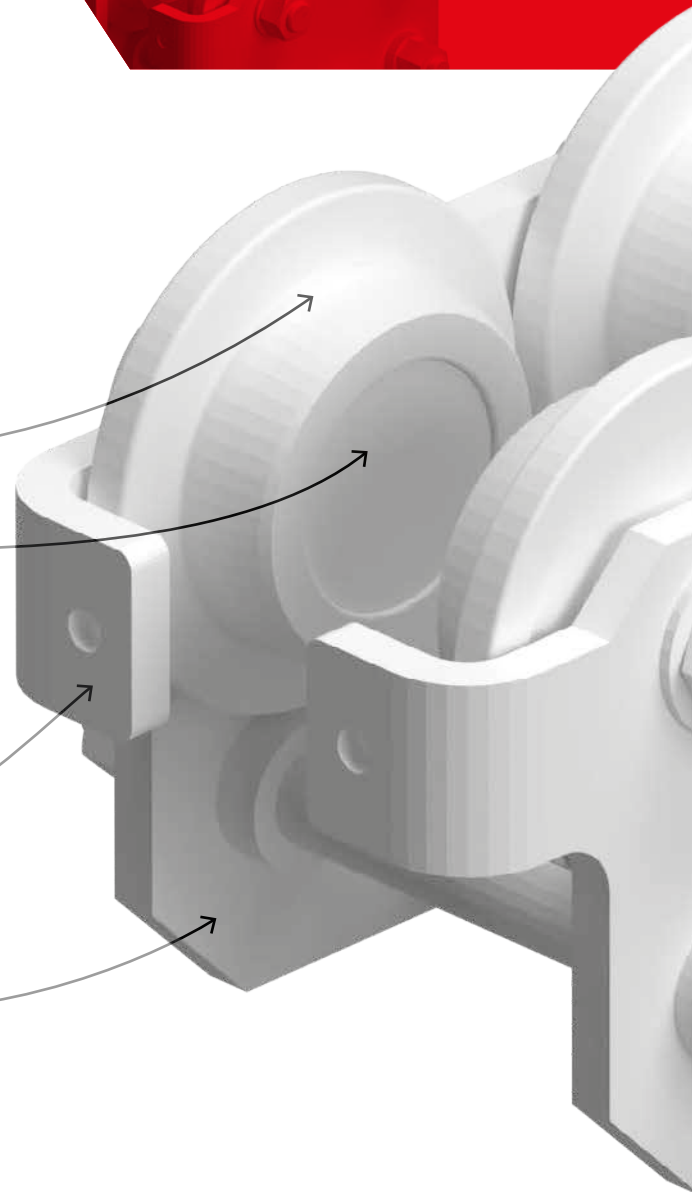

Yugo Central:

De acero, diseñado para poder suspender el polipasto que, de acuerdo a su capacidad, le corresponda.

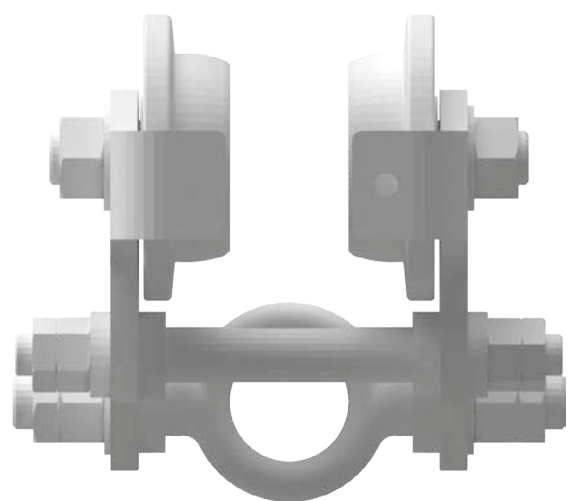

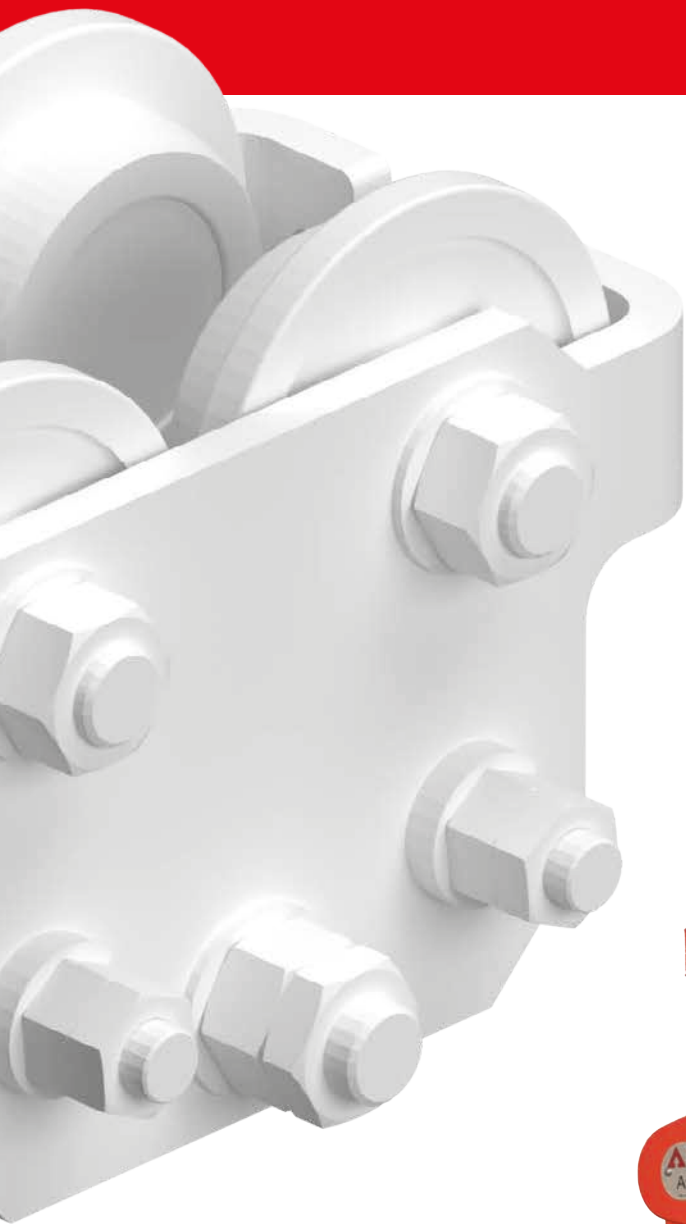

Opciones:

- ▲ Sin traslación "S-T" o con traslación "C-T".
- ▲ Cabezales Articulados, para puentes articulados suspendidos.

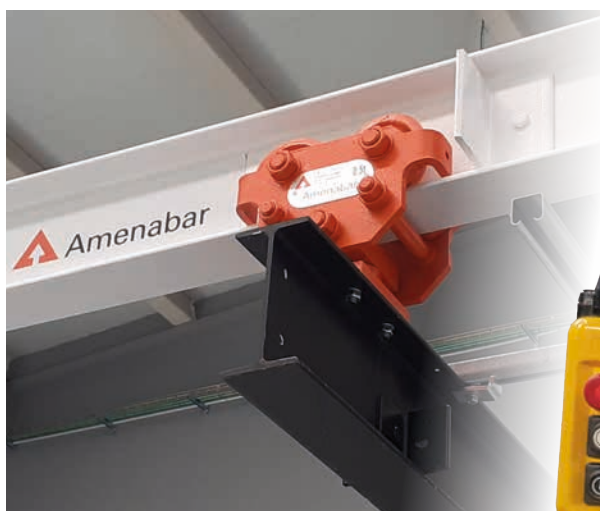

Características y Dimensiones de los Carros Manuales Amenabar

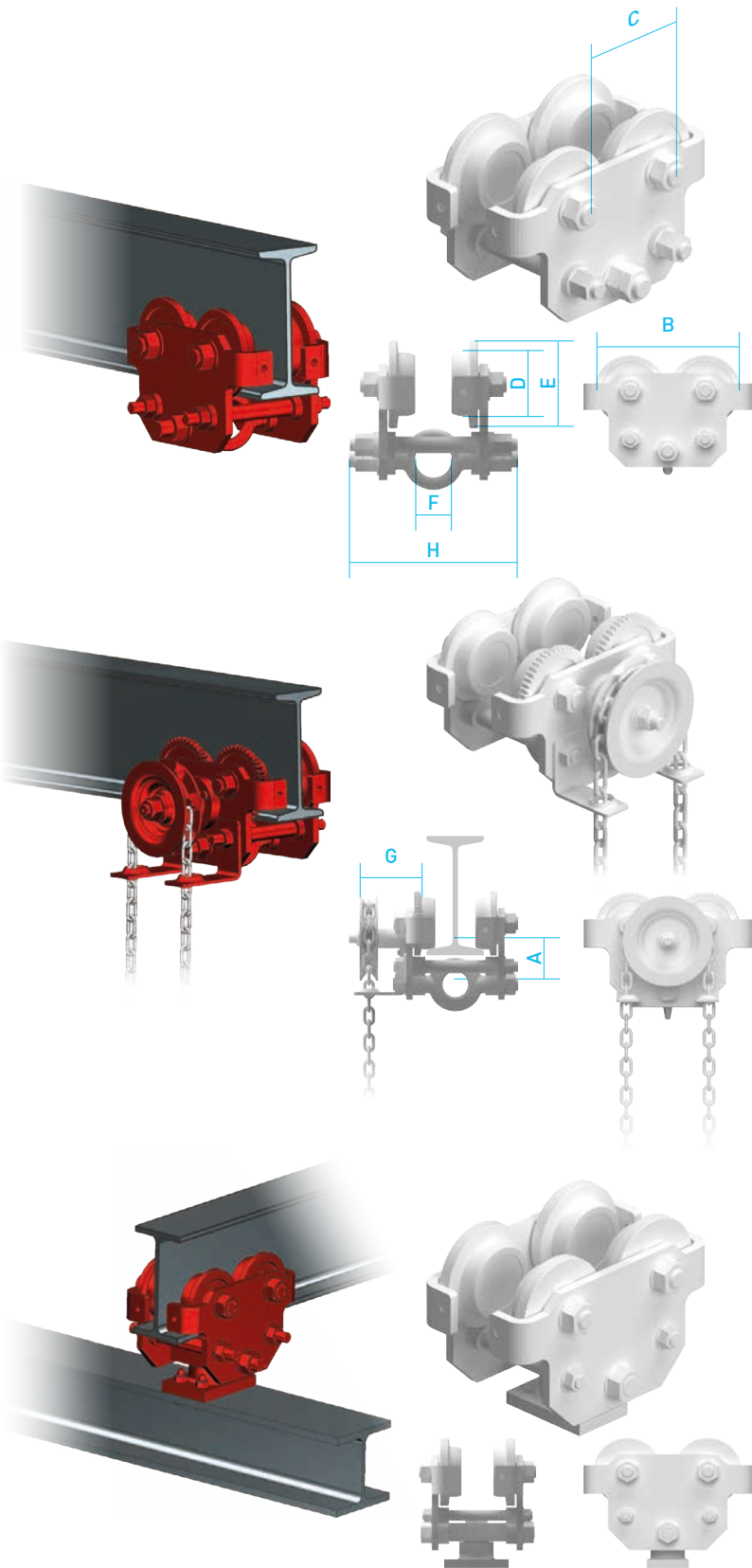

Carros manuales tipo "S-T" (Sin traslación)

Carga	Modelo	Carro "S-T"	Anchura del ala
Kg.		Código	mm.
500	ST	T12005	50 a 82
1.000	ST	T22010	66 a 98
1.600	ST	T32016	74 a 106
2.000	ST	T32020	74 a 106
3.200	ST	T42032	98 a 125

Carros manuales tipo "C-T" (Con traslación)

Carga	Modelo	Carro "C-T"	Anchura del ala
Kg.		Código	mm.
500	CT	T13005	50 a 82
1.000	CT	T23010	66 a 98
1.600	CT	T33016	74 a 106
2.000	CT	T33020	74 a 106
3.200	CT	T43032	98 a 125
5.000	CT	T53050	120 a 150
6.300	CT	T53063	120 a 150
8.000	CT	T63080	135 a 185
10.000	CT	T63100	135 a 185
12.500	CT	T73125	143 a 185
16.000	CT	T73160	143 a 185

Cabezales giratorios manuales

Carga	Modelo	Cabezales MANUALES tipo "S-T"	Anchura del ala
Kg.		Código	mm.
500	ST	T42005	64 a 98
1.000	ST	T42010	74 a 106
2.000	ST	T42020	82 a 113

(*) Verificar la distancia máxima entre cabezales (6 / 8 metros).

Cabezales giratorios eléctricos

Carga	Modelo	Cabezales ELÉCTRICOS	Anchura del ala
Kg.		Código	mm.
500	ET	T52005	64 a 98
1.000	ET	T52010	74 a 106
2.000	ET	T52020	82 a 113

(*) Verificar la distancia máxima entre cabezales (6 / 8 metros).

Carga	Modelo	Peso	Dimensiones							
		Carro "S-T"*	A	B	C	D	E	F	G	H
Kg.		Kg.	mm.	mm.	mm.	mm.	mm.	mm.	mm.	mm.
500	ST	7	60	175	90	62	84	35	90	163
1.000	ST	10	80	210	110	82	100	40	100	195
1.600	ST	15	85	252	130	100	122	40	100	210
2.000	ST	17	95	262	140	100	122	40	110	210
3.200	ST	30	122	308	165	122	142	65	115	250

[*] Verificar viabilidad de su viga en los cuadros de las pág.76 y 77.

Carga	Modelo	Peso	Dimensiones								Cadena maniobra Ø x paso
		Carro "C-T" con 3m.*	A	B	C	D	E	F	G	H	
Kg.		Kg.	mm.	mm.	mm.	mm.	mm.	mm.	mm.	mm.	mm.
500	CT	9	60	175	90	62	84	35	90	163	4x19
1.000	CT	14	80	210	110	82	100	40	100	195	5x21
1.600	CT	19	85	252	130	100	122	40	100	210	5x21
2.000	CT	23	95	262	140	100	122	40	110	210	5x21
3.200	CT	36	122	308	165	122	142	65	115	250	6x27
5.000	CT	48	145	355	185	141	166	85	120	300	6x27
6.300	CT	52	145	355	185	141	166	85	120	300	6x27
8.000	CT	110	190	455	230	184	225	105	130	430	6x27
10.000	CT	120	190	455	230	184	225	105	130	430	6x27
12.500	CT	130	190	455	230	184	225	105	130	440	6x27
16.000	CT	135	190	455	230	184	225	105	130	440	6x27

[*] Verificar viabilidad de su viga en los cuadros de las pág.76 y 77.